

MINISTRY OF EDUCATION AND SCIENCE OF UKRAINE

National aerospace university "Kharkiv Aviation Institute"  
Department of aircraft strength

Course  
Mechanics of materials and structures

HOME PROBLEM 17 a

Internal Forces in Multispan Beams

Name of student:

Group:

Advisor:

Data of submission:

Mark:

National aerospace university  
"Kharkiv Aviation Institute"  
Department of aircraft strength

**Subject:** mechanics of materials  
**Document:** home problem  
**Topic:** Internal Forces in Multispan Beams.

**Full name of the student, group**

---

**Variant: 1**

**Complexity: 1**

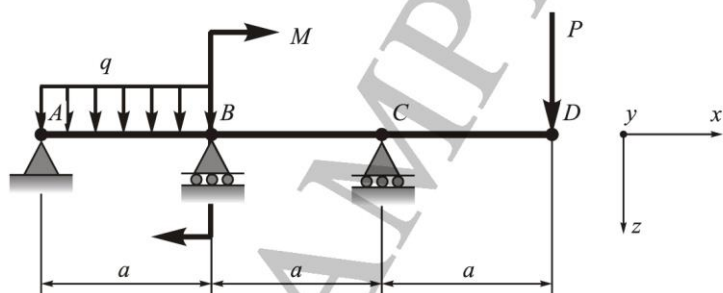

**Given:**  $q = 10 \text{ kN/m}$ ;  $P = 20 \text{ kN}$ ;  $M = 10 \text{ kNm}$ ;  $a = 3 \text{ m}$ .

**Goal:**

1) open static indeterminacy using the equation of three moments and draw the graphs  $Q_z(x)$ ,  $M_y(x)$ .

**signature**

**Full name of the lecturer**

---

**Mark:**

**Given:** two-span beam (see back of cover and Fig. 1),  $M = 10\text{kNm}$ ,  $q = 20\text{kN/m}$ ,  $a = 3\text{m}$ ,  $b = 2\text{m}$ ,  $c = 2\text{m}$ ,  $d = 1\text{m}$ .

**It is necessary:**

- 1) open static indeterminacy using three moment equations and design  $M_y(x)$  and  $Q_z(x)$  diagrams;
- 2) open static indeterminacy using force method and design  $M_y(x)$  and  $Q_z(x)$  diagrams;
- 3) compare the results.

**Solution:**

**(A) Application of the equation of three moments.**

(1) First of all we determine the degree of static indeterminacy according to the formula

$$k = m - n,$$

where  $k$  is the degree of static indeterminacy,  $m$  is the number of unknown reactions,  $n$  is the number of equations of static equilibrium. So,  $m = 4$ ;  $n = 3$  and  $k = 1$ . The fact of the beam being singly statically indeterminate gets obvious.

(2) Designing the equivalent system (see Fig. 1). It is developed by introducing virtual hinge into mid support cross section and adding into it unknown internal bending moment  $M_1 = X_1$ . Also, internal bending moments in left and right supports are represented in equivalent system by two concentrated moments  $M_0$  and  $M_2$ . They are calculated by applying the method of sections using sign conventions shown on Fig. 2.

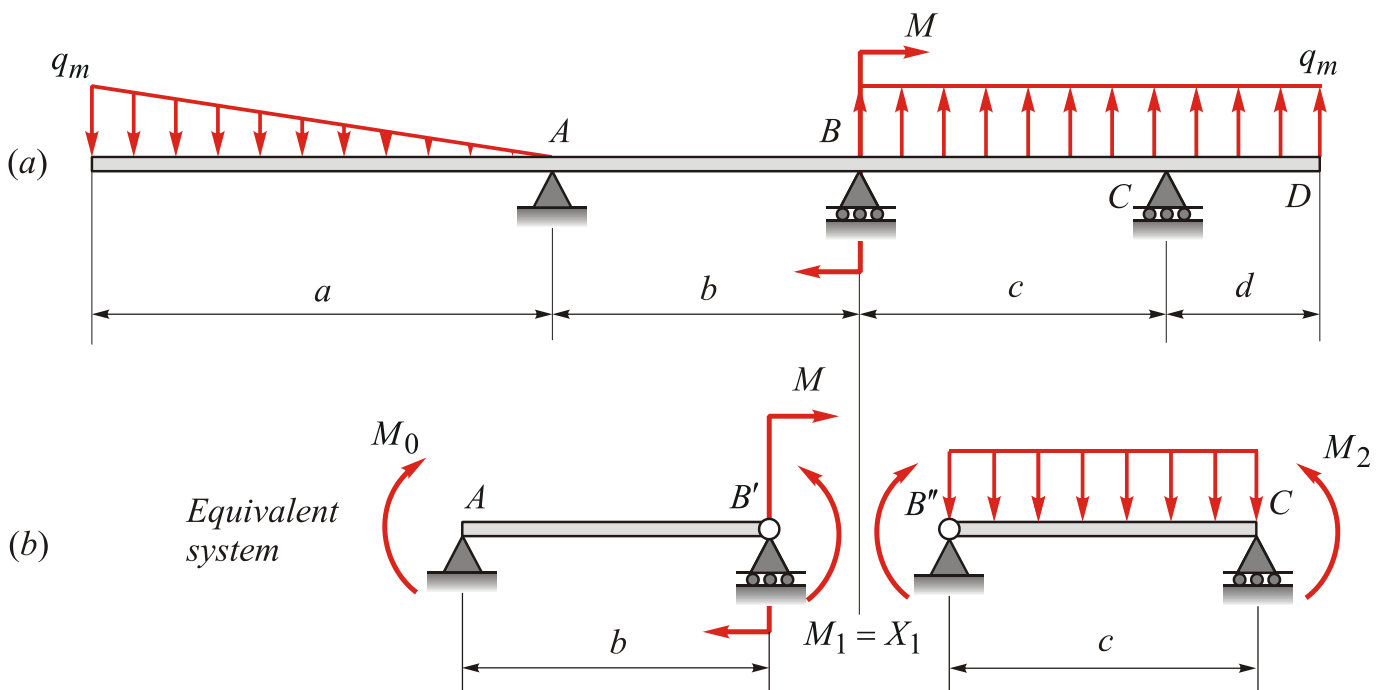

Fig. 1

Note, that the moments  $M_0$ ,  $M_1$ ,  $M_2$  are applied in their positive directions according to the sign conventions, shown on Figs. 2, 3.

Sign conventions:

a) for shear forces

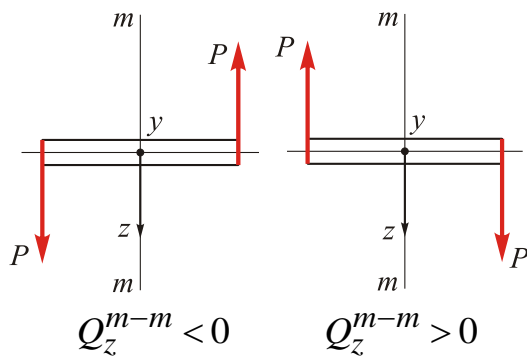

Fig. 2

b) for bending moments

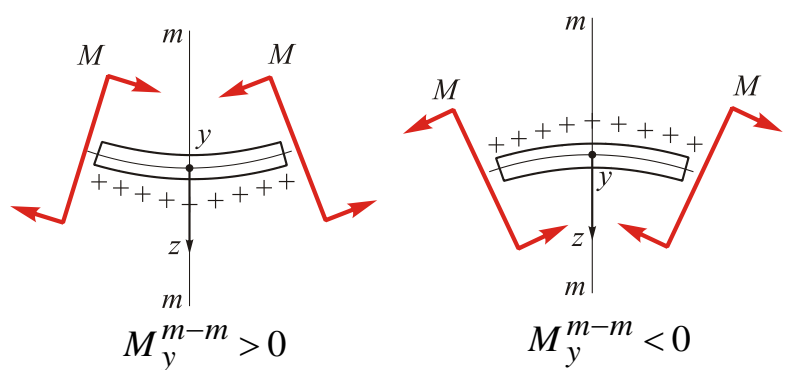

Fig. 3

The values of the moments  $M_0$ ,  $M_2$  are the following:

$$M_0 = -\frac{qa}{2} \times \frac{2}{3}a = -60 \text{ kNm}, \quad M_2 = -\frac{qd^2}{2} = 10 \text{ kNm}.$$

(3) Calculating the unknown bending moment  $M_1$  from the equation of three moments.

In general, the equation of three moments looks like:

$$M_0 l_1 + 2M_1(l_1 + l_2) + M_2 l_2 = -6EI(\alpha + \beta),$$

where  $l_1$  and  $l_2$  are the lengths of the left and right span respectively,  $M_0$  is internal moment in cross-section of left support,  $M_1$  – unknown internal moment in cross-section of middle support,  $M_2$  is internal moment in cross-section of right support.

We have already defined the values of  $M_0$  and  $M_2$ . For our case,  $l_1$  and  $l_2$  are correspondingly the lengths of left and right spans which are equal to  $b = 2 \text{ m}$  and  $c = 2 \text{ m}$ . The angles  $\alpha$ ,  $\beta$  are really the slopes which are generated by only external forces and moments applied correspondingly to the left and right span:  $\alpha$  – angle in right support of left span and  $\beta$  – in left support of right span. **Note, that external forces and moments which were earlier included into  $M_0$ ,  $M_2$  calculating, should not be included into  $\alpha$ ,  $\beta$  calculating.** Left and right spans are shown on Figs 4 and 5 with corresponding shapes of deflected curve under loading mentioned above. Due to the  $M$  external moment is applied in midsection, it may be considered as the deflection generator of left or right span, depending on our wish. In this solution, we will assume the  $M$  moment be applied to left span. **Note also, that the angles corresponding to convex deflection are assumed to be positive in three moment equation and vice versa.**

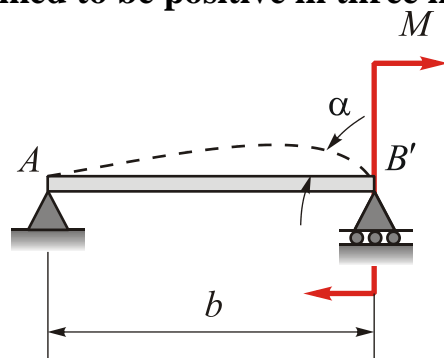

Fig. 4

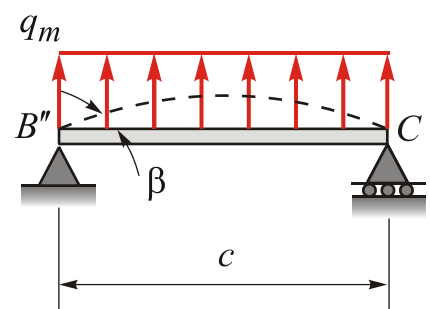

Fig. 5

(a) Let us define the  $\alpha$  and  $\beta$  angles using well-known formula from teaching aids:

$$\alpha < 0 \quad \alpha = -\frac{Mb}{3EI} = -\frac{20}{3EI} \left[ \frac{\text{kNm}^2}{EI} \right].$$

Note, that  $\alpha < 0$  due to concave shape of left span deflection curve which is assumed to be negative in proving three moment equation. Due to this assumption  $\beta$  angle will also be negative:

$$\beta < 0 \quad \beta = -\frac{qc^3}{24EI} = -\frac{20}{3EI} \left[ \frac{\text{kNm}^2}{EI} \right].$$

(b) Let us define the  $\alpha$  and  $\beta$  angles using Mohr's method. For this purpose, we will consider the left and right spans under external loadings as the force systems ( $F$ ) and will design two corresponding unit systems applying unit dimensionless moment  $\bar{M} = 1$  in right support of the left span (to calculate  $\alpha$  angle) and unit dimensionless moment  $\bar{M} = 1$  in left support of the right span (to calculate  $\beta$  angle). **Note, that unit moments are applied in arbitrary directions and results of calculation may be positive or negative depending on the  $\bar{M} = 1$  direction.**

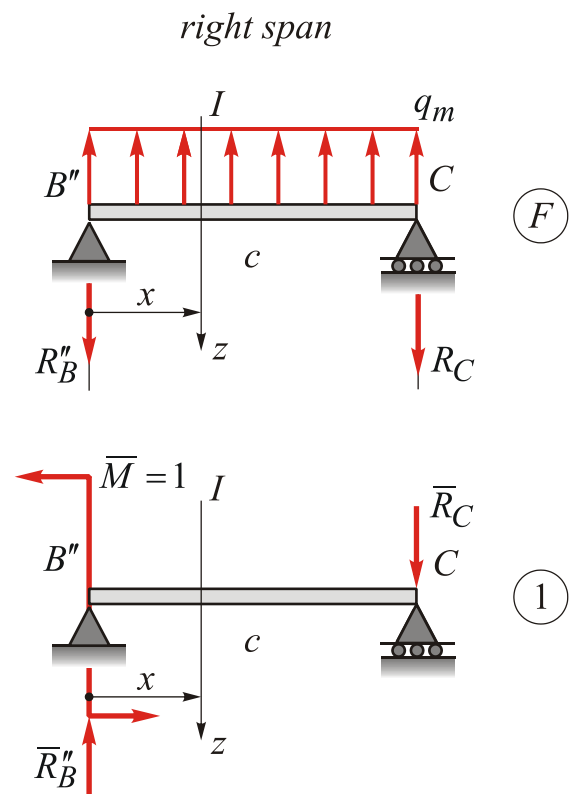
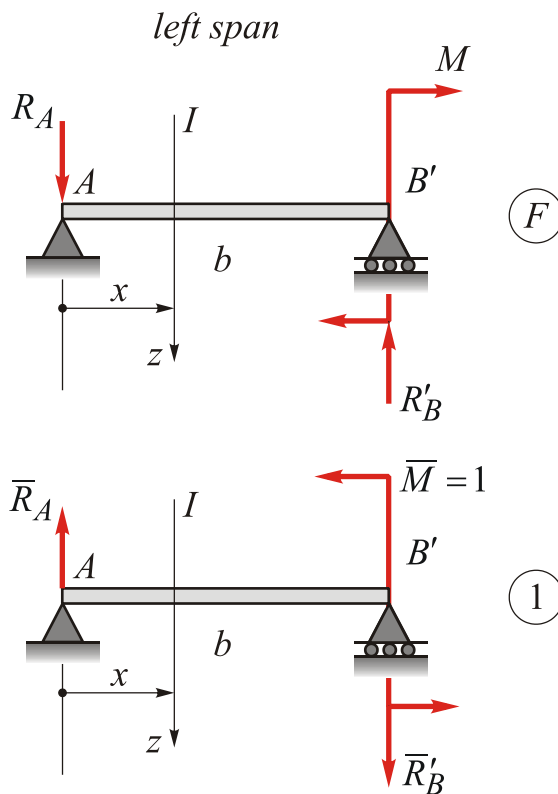

Calculating the reactions in the unit systems (**clockwise rotation is assumed to be positive**):

$$\begin{aligned} \text{left span} \quad \sum M_{B'} = 0 &= -\bar{R}_A b + \bar{M} \rightarrow \bar{R}_A = 1/b = 0.5 \text{ m}, \quad \bar{R}_{B'} = \bar{R}_A = 0.5 \text{ m}, \\ \text{right span} \quad \sum M_{B''} = 0 &= \bar{R}_C c - \bar{M} \rightarrow \bar{R}_C = 1/c = 0.5 \text{ m}, \quad \bar{R}_{B''} = \bar{R}_C = 0.5 \text{ m}. \end{aligned}$$

Calculating the reactions in the force systems:

$$\text{left span } \sum M_{B'} = 0 = -R_A b + M \rightarrow R_A = M/b = 10/2 = +5 \text{ kN}, \quad R_{B'} = +5 \text{ kN},$$

$$\text{right span } \sum M_{B''} = 0 = R_C c - q_m c^2 / 2 \rightarrow R_C = +20 \text{ kN}, \quad R_{B''} = R_C = +20 \text{ kN}.$$

Equations of bending moments are the following:

$$\text{left span } M_{yF}^I(x) = -R_A x = -5x,$$

$$\bar{M}_y^I(x) = \bar{R}_A x = 0.5x.$$

$$\text{right span } M_{yF}^I(x) = qx^2 / 2 - R_B'' x = (10x^2 - 20x),$$

$$\bar{M}_y^I(x) = -\bar{M} + \bar{R}_B'' x = (-1 + 0.5x).$$

Results of the Mohr's method calculations are:

$$\alpha = \frac{1}{EI} \left[ \int_0^b (-5x)(0.5x) dx \right] = \frac{1}{EI} \left[ -2.5 \frac{b^3}{3} \right] = -\frac{20}{3EI},$$

$$\beta = \frac{1}{EI} \left[ \int_0^c (10x^2 - 20x)(-1 + 0.5x) dx \right] = +\frac{20}{3EI}.$$

Taking into account the notations mentioned above, negative values of these angles,

i.e.  $\alpha = -\frac{20}{3EI}$  and  $\beta = -\frac{20}{3EI}$  are substituted into three moment equation:

$$(-60) \times 2 + 2M_1(2+2) + (+10) \times 2 = -6EI \left( -\frac{20}{3EI} - \frac{20}{3EI} \right).$$

After substituting we obtain the result:  $M_1 = +22.5 \text{ kNm}$ . It means that static indeterminacy of specified beam is opened and it is possible to determine the internal forces in equivalent system shown on Fig. 1. **Note, that in the case of negative  $M_1$  value it should be applied to both spans of equivalent system in opposite directions.**

(4) Considering the left and right spans separately and constructing the internal force factors diagrams for each of them. The spans are shown on Figs. 8 and 9.

(a) left span (see Fig. 8). **Note, that clockwise rotation is assumed to be positive in the reactions calculating.**

$$\sum M_{B'} = 0: \quad -\frac{q_m a}{2} \left( \frac{2}{3} a + b \right) + R_{A_{orig}} b + M - M_1 = 0.$$

$$R_{A_{orig}} = \frac{1}{b} \left( M_1 - M + \frac{q_m a}{2} \left( \frac{2}{3} a + b \right) \right) = \frac{1}{2} \left( 22.5 - 10 + \frac{30 \times 2}{2} \left( \frac{2}{3} \times 2 + 2 \right) \right) = +66.25 \text{ kN}$$

(actual direction upwards).

$$\sum M_A = 0: \quad -\frac{q_m a^2}{3} + R'_{B_{orig}} b + M - M_1 = 0.$$

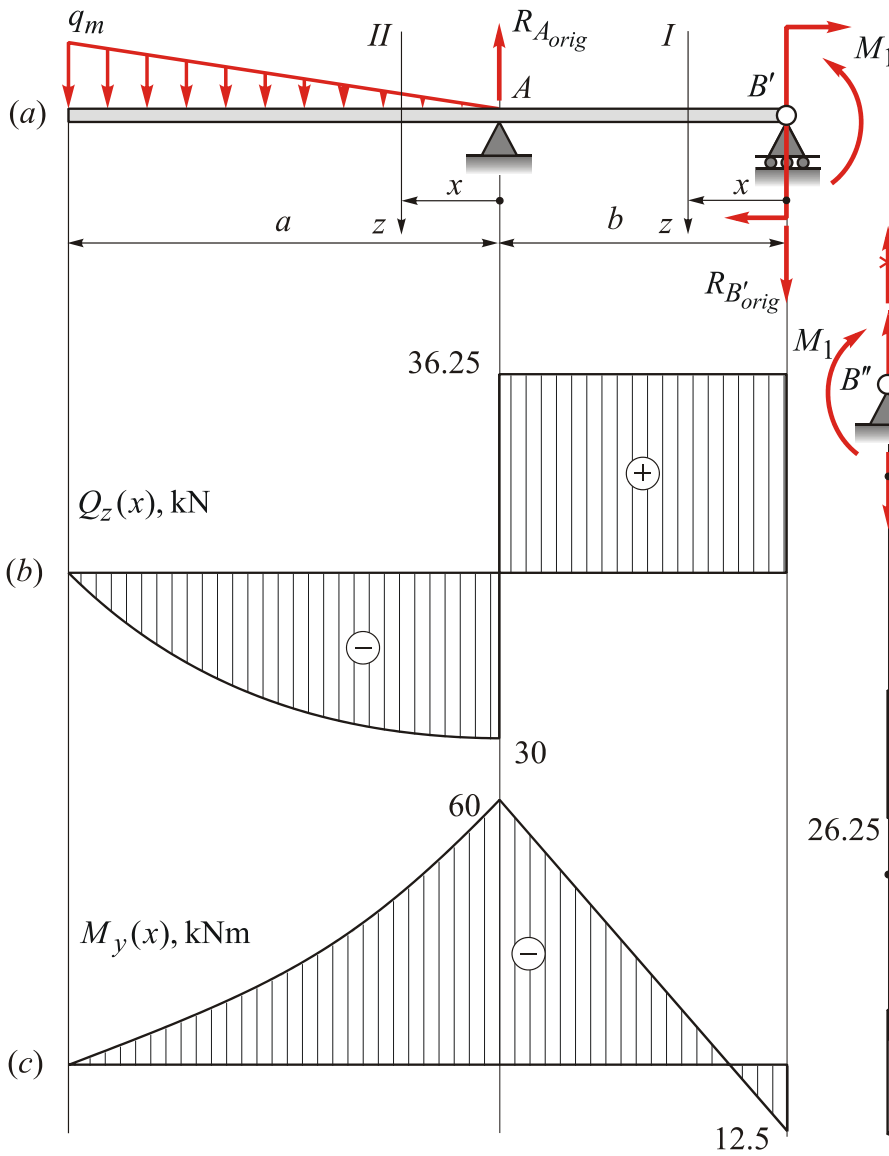

Fig. 8

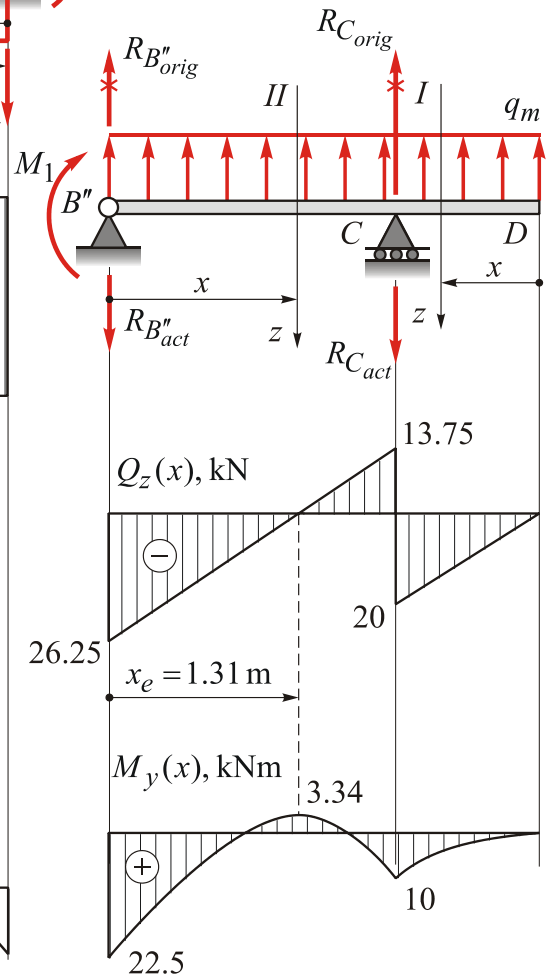

Fig. 9

$$R_{B'orig} = \frac{1}{b} \left( M_1 - M + \frac{q_m a^2}{3} \right) = \frac{1}{2} \left( 22.5 - 10 + \frac{30 \times 4}{2} \right) = +36.25 \text{ kN}$$

(actual direction downwards).

Checking:

$$\sum F_z = 0: \quad +\frac{q_m a}{2} - R_{Aorig} + R'_{Borig} = 0 \quad \rightarrow \quad +\frac{20 \times 3}{2} - 66.25 + 36.25 = 0.$$

Equations of internal forces are the following:

I - I:  $0 \leq x \leq b$

$$Q_z^I(x) = R'_{Borig} = +36.25 \text{ kN},$$

$$M_y^I(x) = -R'_{Borig} x - M + M_1 \Big|_{x=0} = 12.5 \Big|_{x=2} = -60 \text{ kNm}.$$

II - II:  $0 \leq x \leq a$

$$Q_z^{II}(x) = R'_{Borig} - R_{Aorig} + \frac{q_m x^2}{2a} \Big|_{x=0} = -30 \Big|_{x=a} = 0,$$

$$M_y^{II}(x) = -R'_{Borig} (x+b) - M + M_1 + R_{Aorig} x - \frac{q x^3}{6a} \Big|_{x=0} = -60 \Big|_{x=a} = 0.$$

(b) right span (see Fig. 9). **Note, that clockwise rotation is assumed to be positive in the reactions calculating.**

$$\sum M_c = 0: -\frac{q_m d^2}{2} + \frac{q_m c^2}{2} + R_{B_{orig}}'' c + M_1 = 0.$$

$$R_{B_{orig}}'' = \frac{1}{c} \left( +\frac{q_m d^2}{2} - \frac{q_m c^2}{2} - M_1 \right) = \frac{1}{2} \left( \frac{20 \times 1}{2} - \frac{20 \times 4}{2} - 22.5 \right) = -26.25 \text{ kN}$$

(actual direction downwards).

$$\sum M_{B''} = 0: -R_{C_{orig}} c + M_1 - \frac{q_m}{2} (c + d)^2 = 0.$$

$$R_{C_{orig}} = \frac{1}{c} \left( M_1 - \frac{q_m}{2} (c + d)^2 \right) = \frac{1}{2} \left( 22.5 - \frac{20}{2} (2 + 1)^2 \right) = -33.75 \text{ kN}$$

(actual direction downwards).

Checking:

$$\sum F_z = 0: -q(c + d) + R_{C_{act}} + R_{B_{act}}'' = 0 \rightarrow -60 + 33.75 + 26.25 = 0.$$

Equations of internal forces are the following:

$$I - I: 0 \leq x \leq d$$

$$Q_z^I(x) = -q_m x \Big|_{x=0} = 0 \Big|_{x=d} = -20 \text{ (kN)},$$

$$M_y^I(x) = \frac{q_m x^2}{2} \Big|_{x=0} = 0 \Big|_{x=d} = 10 \text{ (kNm)}.$$

$$II - II: 0 \leq x \leq c$$

$$Q_z^{II}(x) = -R_{B_{act}}'' + q_m x \Big|_{x=0} = -26.25 \Big|_{x=c} = 13.75 \text{ kN},$$

$$M_y^{II}(x) = M_1 - R_{B_{act}}'' x + \frac{q_m x^2}{2} \Big|_{x=0} = 22.5 \Big|_{x=c} = 10 \text{ kNm}.$$

Extremal bending moment calculating:

$$Q_z^{II}(x_e) = -R_{B_{act}}'' + q x_e = 0 \rightarrow x_e = \frac{R_{B_{act}}''}{q_m} = \frac{26.25}{20} = 1.31 \text{ m}.$$

$$M_y^{II}(x_e) = M_{y_{\max}}^{II} = M_1 - R_{B_{act}}'' x_e + \frac{q_m x_e^2}{2} = 10 - 26.25 \times 1.31 + 20 \times 1.31^2 / 2 = -3.34 \text{ (kNm)}.$$

By connecting the graphs of internal forces for two spans we get the solution of the problem shown on Fig. 10.

### (B) Solution by the force method.

First of all let us choose the base system (BS) and design corresponding equivalent system (ES) (see Fig. 11). Designing correspondent equivalent system is also shown on Fig. 11. The effect of middle support is replaced in equivalent system by unknown reaction (force)  $X_1$ . Its value must be found using the equation of deflection compatibility, which is represented as **canonical equation of the force method**. Their geometrical sense is in total zero vertical deflection of vertically immobile  $B$  point of equivalent system. This deflection is really a geometric sum of the  $B$ -point deflection generated by external forces and, secondly, by unknown  $X_1$  force. This canonical equation has the shape:

$$\delta_{\text{vert } p.B} (X_1, F) = 0 \quad \text{or} \quad \delta_{11} X_1 + \Delta_{1F} = 0.$$



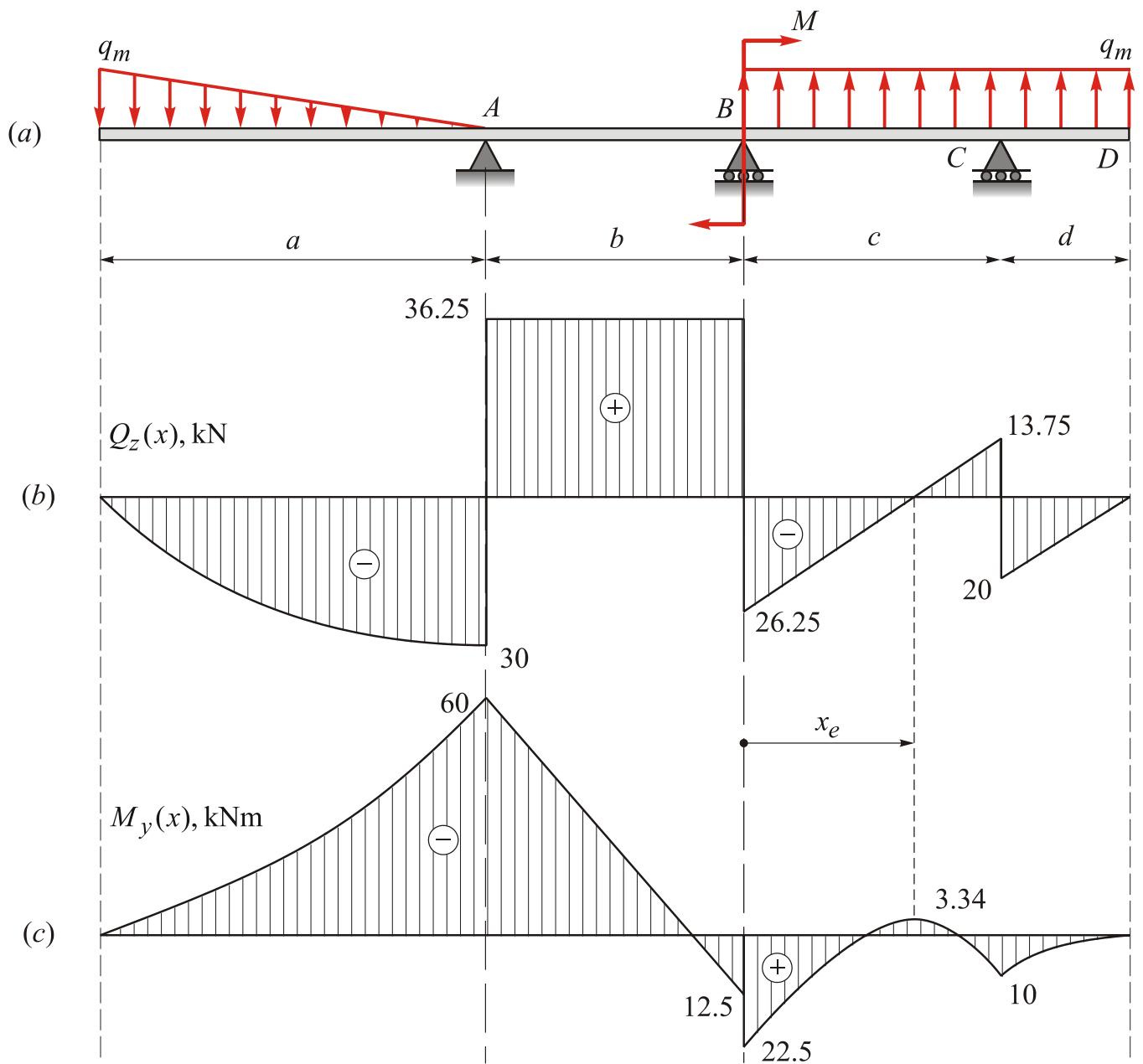

Fig. 10

To find two coefficients  $\delta_{11}$  and  $\Delta_{1F}$  it is necessary to design the force ( $F$ ) and unit (1) systems. They are shown on Fig. 11. **Note, that the force system is the base system with only external forces applied. Unit system is the base system with unit  $\bar{X}_1$  force applied.** They are shown on Fig. 11.

The unknown reactions  $R_A$  and  $R_C$  in the force system ( $F$ ) we will calculate using the equations of statics:

$$\sum M_A = 0 = -\frac{q_m a}{2} \times \frac{2}{3} a + M + R_C (b+c) - q_m (c+d) \left( \frac{c+d}{2} + b \right).$$

$$R_C = \frac{1}{b+c} \left( \frac{q_m a^2}{3} - M + q_m (c+d) \left( \frac{c+d}{2} + b \right) \right) = \frac{1}{4} \left( \frac{20 \times 9}{3} - 10 + 20 \times 3 \left( \frac{3}{2} + 2 \right) \right) = +65 \text{ kN}$$

(actual direction downwards).

$$\sum M_C = 0 = -\frac{q_m a}{2} \times \left( \frac{2}{3} a + b + c \right) + M + R_A (b+c) + \frac{q_m c^2}{2} - \frac{q_m d^2}{2}.$$

$$R_A = \frac{1}{b+c} \left( \frac{q_m a}{2} \left( \frac{2}{3} a + b + c \right) - M - \frac{q_m c^2}{2} + \frac{q_m d^2}{2} \right) =$$

$$= \frac{1}{4} \left( \frac{20 \times 9}{2} \left( \frac{2}{3} \times 3 + 2 + 2 \right) - 10 - \frac{20 \times 4}{2} + \frac{20 \times 1}{2} \right) = +35 \text{ kN}$$

(actual direction upwards).

$$\text{Checking: } \sum F_z = 0 = \frac{q_m a}{2} - q_m (c + d) - R_A + R_C = \frac{20 \times 3}{2} - 20(2 + 1) - 35 + 65 = 0.$$

The unknown reactions  $\bar{R}_A$  and  $\bar{R}_C$  in the unit system (1) we will also calculate using the equations of statics:

$$\sum M_A = 0 = +\bar{R}_C (b + c) - \bar{X}_1 b = 0 \rightarrow \bar{R}_C = \frac{1}{2} \text{ (dimensionless)}$$

(actual direction upwards).

$$\sum M_C = 0 = -\bar{R}_A (b + c) + \bar{X}_1 c = 0 \rightarrow \bar{R}_A = \frac{1}{2} \text{ (dimensionless)}$$

(actual direction upwards).

$$\text{Checking: } \sum F_z = 0 = \bar{R}_A + \bar{R}_C - \bar{X}_1 = \frac{1}{2} + \frac{1}{2} - 1 = 0.$$

Equations of internal forces in the force and unit systems are the following:

$$I - I: 0 \leq x \leq d$$

$$M_{yF}^I(x) = \frac{q_m x^2}{2} = (10x^2),$$

$$\bar{M}_y^I(x) = 0.$$

$$II - II: 0 \leq x \leq c$$

$$M_{yF}^{II}(x) = q_m d \left( \frac{d}{2} + x \right) + \frac{q_m x^2}{2} - R_C x = (10 - 45x + 10x^2),$$

$$\bar{M}_y^{II}(x) = \left( -\frac{x}{2} \right).$$

$$III - III: 0 \leq x \leq b$$

$$M_{yF}^{III}(x) = q_m d \left( \frac{d}{2} + c + x \right) + q_m c \left( \frac{c}{2} + x \right) - R_C (c + x) - M = (-50 - 5x),$$

$$\bar{M}_y^{III}(x) = \left( -1 + \frac{x}{2} \right).$$

$$IV - IV: 0 \leq x \leq a$$

$$M_{yF}^{IV} = q_m d \left( \frac{d}{2} + c + b + x \right) + q_m c \left( \frac{c}{2} + b + x \right) - R_C (c + b + x) - M + R_A x - \frac{q_m x^3}{6a} =$$

$$= - \left( \frac{10}{9} x^3 + 30x - 60 \right),$$

$$\bar{M}_y^{IV}(x) = 0.$$



$$Q_z^{II}(x) = -q_m(x+d) + R_{C_{act}}^* = -20(x+1) + 33.75 =$$

$$= (-20x + 13.75) \Big|_{x=0} = +13.75 \Big|_{x=2} = -26.25 \text{ kN},$$

$$M_y^{II}(x) = +q_m(d+x) \frac{(d+x)}{2} - R_{C_{act}}^* x =$$

$$= (10x^2 - 13.75x + 10) \Big|_{x=0} = +10 \Big|_{x=2} = +22.5 \text{ kNm}.$$

Due to  $Q_z^{II}(x)$  function changes its sign from "plus" to "minus" it is necessary to find  $M_y^{II}(x)$  extremal value:

(a) extremum coordinate finding by equating to zero  $Q_z^{II}(x)$  function:

$$Q_z^{II}(x_e) = (-20x_e + 13.75) = 0 \rightarrow x_e = +\frac{13.75}{20} = +0.69 \text{ m}.$$

(b) calculating  $M_{y_{\max}}^{II}$  value substituting  $x_e$  value into  $M_y^{II}(x)$  equation:

$$M_y^{II}(x_e) = M_{y_{\max}}^{II} = (10x_e^2 - 13.75x_e + 10) = -3.34 \text{ kNm}.$$

*III – III*:  $0 < x < b$

$$Q_z^{III}(x) = R_{C_{act}}^* - q_m(c+d) + X_1 = +36.25 \text{ kN},$$

$$M_y^{III}(x) = -R_{C_{act}}^*(c+x) - M - X_1x + q_m(c+d) \left( \frac{c+d}{2} + x \right) =$$

$$= (12.5 - 36.25x) \Big|_{x=0} = 12.5 \Big|_{x=2} = -60 \text{ kNm}.$$

*IV – IV*:  $0 < x < a$

$$Q_z^{IV}(x) = R_{C_{act}}^* - q_m(c+d) + X_1 + \frac{q_mx^2}{2a} - R_{A_{orig}}^* = \left( \frac{10}{3}x^2 - 30 \right) \Big|_{x=0} = -30 \Big|_{x=3} = 0 \text{ kN}$$

$$M_y^{IV}(x) = -R_{C_{act}}^*(c+b+x) + q_m(c+d) \left( \frac{c+d}{2} + b+x \right) - M -$$

$$-X_1(b+x) + R_{A_{orig}}^* x - \frac{q_mx^3}{6a} = \left( -\frac{10}{9}x^3 + 30x - 60 \right) \Big|_{x=0} = -60 \Big|_{x=3} = 0 \text{ kNm}.$$

The  $Q_z(x)$  and  $M_y(x)$  graphs are represented on Fig. 11 (f, g).

**General conclusion.** Due to  $X_1$  force is really the reaction in middle support, it may be compared with the “abrupt” on the shear force graph, designed in result of first solution applying three moment equation. This “abrupt” is equal to  $(36.25 + 26.25 = 62.5 \text{ kN})$ . It’s coincidence with the value of  $X_1$  force supports the accuracy of this problem solution.

The “abrupt” on the  $M_y(x)$  graph in  $B$ -point is equal to external  $M$  value 10 kNm and internal moment in  $B$  section (equal to 22.5 kNm) is really unknown  $M_1$  moment which has been found earlier in three moment equation.

Totally, the graphs of  $Q_z(x)$  and  $M_y(x)$  shown on the Figs. 10 and 11 are identical.

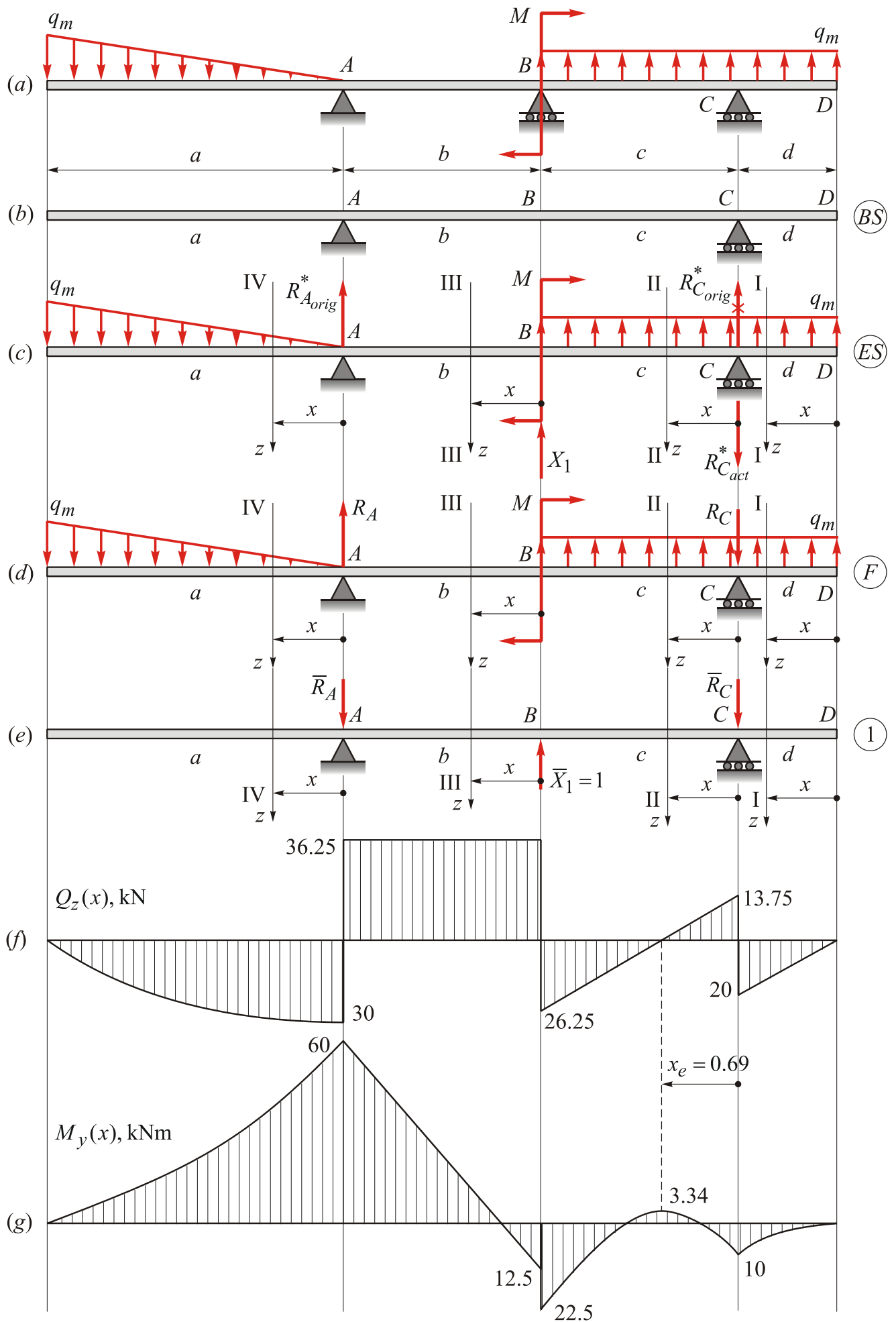

Fig. 11